

Rev.	Date	Notes
A	10-01-09	Initial Release

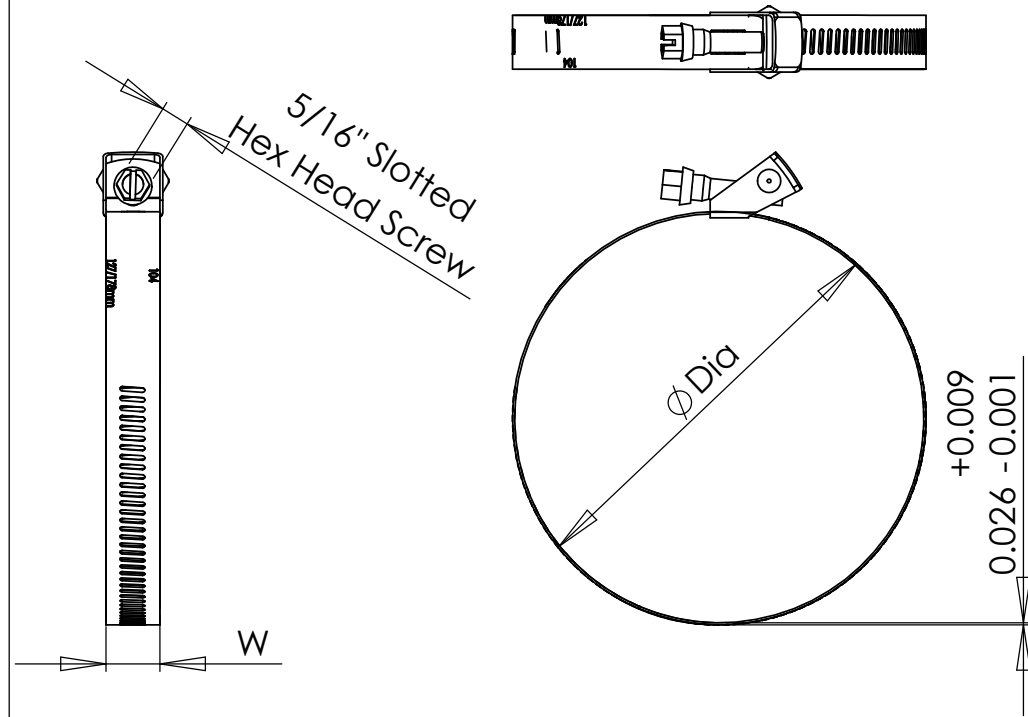

PART NO	MIN DIA	MAX DIA	W
QR-104	1-3/4"	7"	1/2"
QR3-104	1-3/4"	7"	9/16"
QR-128	1-3/4"	8-1/2"	1/2"
QR3-128	1-3/4"	8-1/2"	9/16"
QR-152	1-3/4"	10"	1/2"
QR3-152	1-3/4"	10"	9/16"
QR-188	1-3/4"	12-1/4"	1/2"
QR3-188	1-3/4"	12-1/4"	9/16"
QR-232	1-3/4"	15"	1/2"
QR3-232	1-3/4"	15"	9/16"
QR-258	1-3/4"	16-1/4"	1/2"
QR3-258	1-3/4"	16-1/4"	9/16"
QR-288	1-3/4"	18-1/2"	1/2"
QR3-288	1-3/4"	18-1/2"	9/16"
QR-312	1-3/4"	20"	1/2"
QR3-312	1-3/4"	20"	9/16"



PROPRIETARY AND CONFIDENTIAL
 THE INFORMATION CONTAINED IN THIS DRAWING IS THE SOLE PROPERTY OF **CODA RESOURCES**. ANY REPRODUCTION IN PART OR AS A WHOLE WITHOUT THE WRITTEN PERMISSION OF **CODA RESOURCES** IS PROHIBITED.

Notes:

1. RoHS Compliant - No Hexavalent Chromium - Cr(VI)
2. Durability Torque 80 in-lbsMin
3. All surfaces to be clean and polished
4. Parts to be free of burrs and sharp edges
5. Material: Band and Housing - 200 Series Stainless Steel
Screw - Zinc Plated

NAME	DATE	CODA RESOURCES 960 Alabama Ave, Brooklyn, NY 11207 P:718-649-1666 F:718-485-4403	
DRAWN	RH 10-1-09		
UNLESS OTHERWISE SPECIFIED:		TITLE:	
DIMENSIONS ARE IN INCHES [] DENOTES MILLIMETER TOLERANCES x.xx ± 0.02 [0.51] x.xxx ± 0.005 [0.13]		Heavy Duty PBP Series Quick Release Clamps	
MATERIAL	See Notes	SIZE	DWG. NO.
FINISH	Semi-Polished	A	QR Hose Clamps PBP Rev A
DO NOT SCALE DRAWING	SCALE: 1:2		REV A
			SHEET 1 OF 1